

Modulation Identification Using Neural Networks for Cognitive Radios

Bin Le, Thomas W. Rondeau,
David Maldonado, and Charles W. Bostian

binle@vt.edu

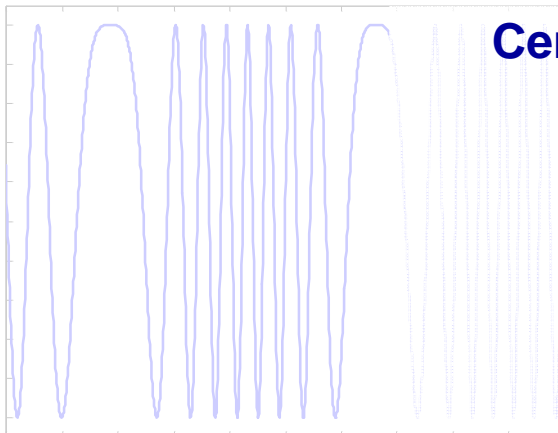

Center for Wireless Telecommunications
466 Whittemore Hall
Blacksburg, VA 24061
Virginia Tech

11/16/2005

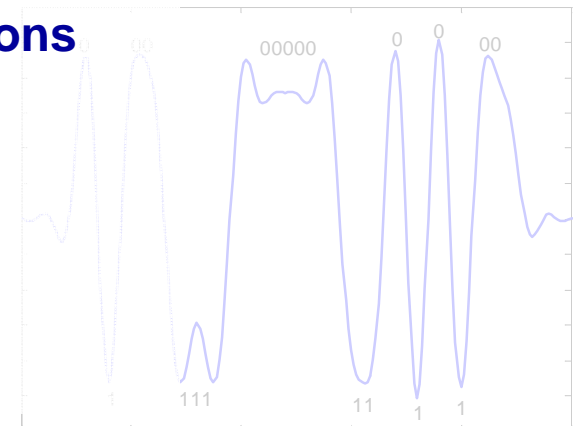

Presentation Outline

- Cognitive radio (CR) overview
- Synchronization for CR
- Modulation classification
- Neural network for modulation identification
- Waveform feature space analysis

Cognitive Radio

- Cognitive radios (CRs) are intelligent communications devices that are aware of the external environment and user needs to reconfigure themselves to optimize quality of service (QoS).
- Physical (PHY) and MAC layer agility
- Cross-layer performance optimization

Radio Environment Awareness

- Radio-domain-specific cognition over SDR platform
 - Radio environment recognition
 - Radio operation adaptation
- Propagation channel modeling and tracking
- Spectrum sensing and understanding
- Waveform recognition and modulation identification

Universal Waveform Recognition

- Standard-based or standard-free waveform recognition
- System-wide cognitive receiver design

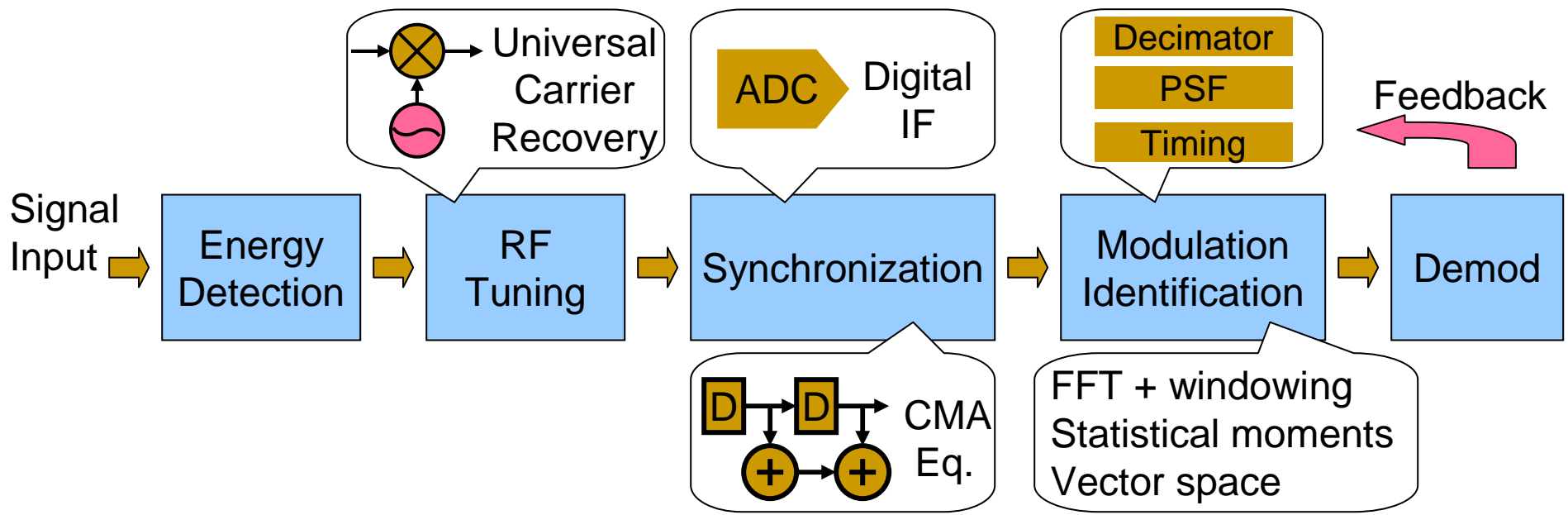

General Synchronization Design Challenge

- Carrier recovery is modulation-specific or pilot-aided
- Symbol timing is data-aided
- Equalization is based on known link standard
- Demodulation is after known matched filter
- System-level design reform is needed for universal synchronization

Communication Signal Analysis Methods

- A hybrid, hierarchical signal feature classification approach is designed
 - Where: digital IF and baseband
 - Methods: temporal, spectral, and vector space
 - How: using neural network for signal classification

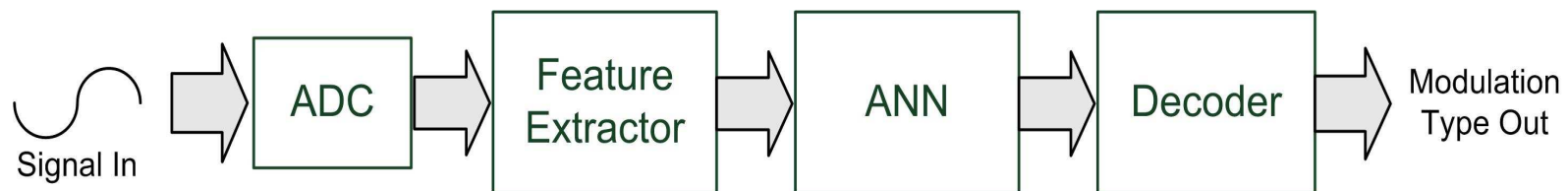

Waveform Features

- Temporal statistical features
 - Statistical moments with different orders
 - User-defined metrics based on basic statistics
- Spectral statistical features
 - Power spectral density (PSD)
 - Cyclostationarity features
- Vector-space features
 - Constellation distribution
 - Complex phase swing and rotation

Design Considerations

- Suitability for embedded DSP
- Efficiency for low-power on-line processing
- Adaptation for wireless channel variations
- Flexibility for reconfigurability and hardware compatibility
- Robustness for reliable performance

Modulation Classifier Options

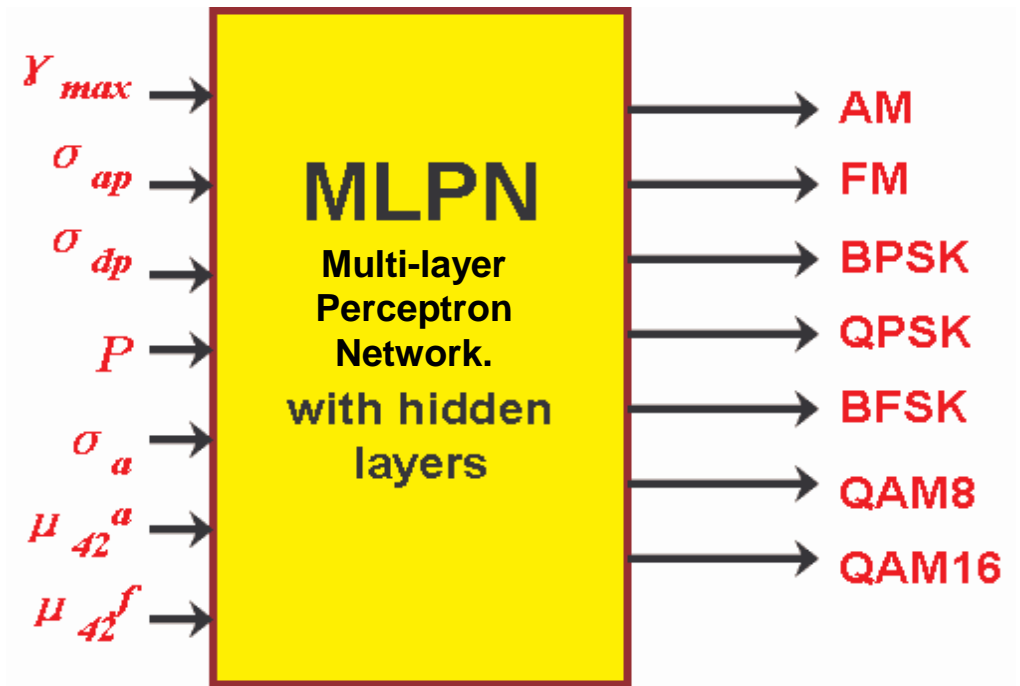
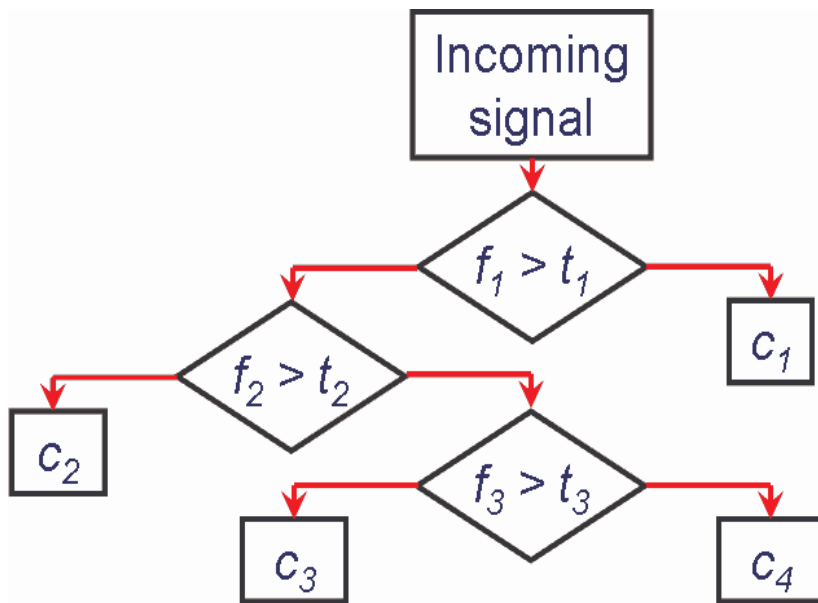

- Decision theoretic
 - Threshold control
 - Error misleading
 - Difficult to reconfigure

- Ad-hoc direct classify
 - Input encoding
 - Training needed
 - Network configuration

Neural Networks for Direct Classification

- Parallel distributed processing (PDP) nature
- Flexibility in topology and connection configuration
- Arbitrary nonlinear mapping capability
- Simplicity for on-line processing
- Self-learning and adaptation
- Robust against noisy inputs

One-class-one-network (OCON)

- Multi-layer perceptron network (MLPN)
 - Large, heavy computation, slow
- OCON with maxnet decision maker
 - 2-layer (5+1) small sub-net for each modulation
 - Simple voting at maxnet output
 - Easy to reconfigure, and VERY fast
 - Ideal for DSP implementation

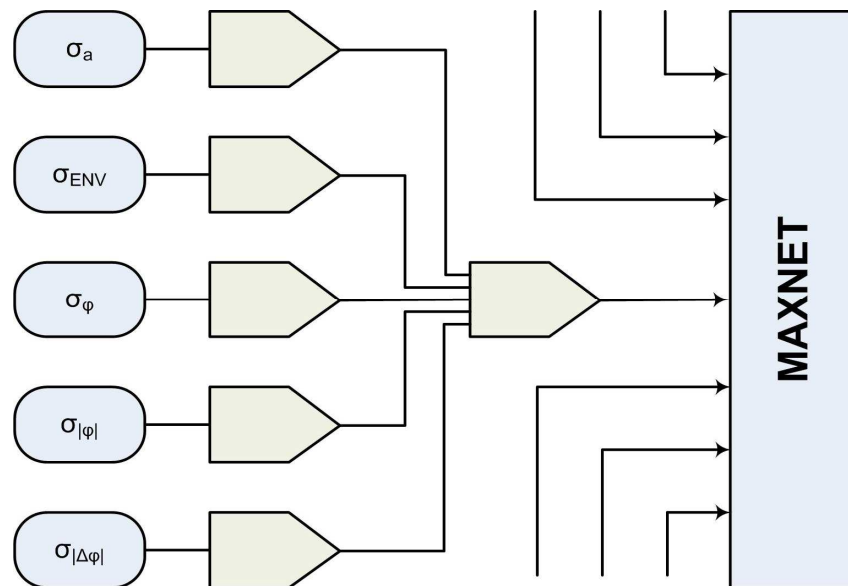

Waveform Features

$$s(t) = A(t)g(t)\cos(2\pi f(t)t + \phi(t)) = A(t)g(t)\operatorname{Re}\left\{e^{j\phi(t)}e^{j2\pi f(t)t}\right\}$$

- Modulating mechanisms define how amplitude, frequency and phase vary, not their values
- Waveform changes in time and frequency
- Signal constellation moves in real and complex domain

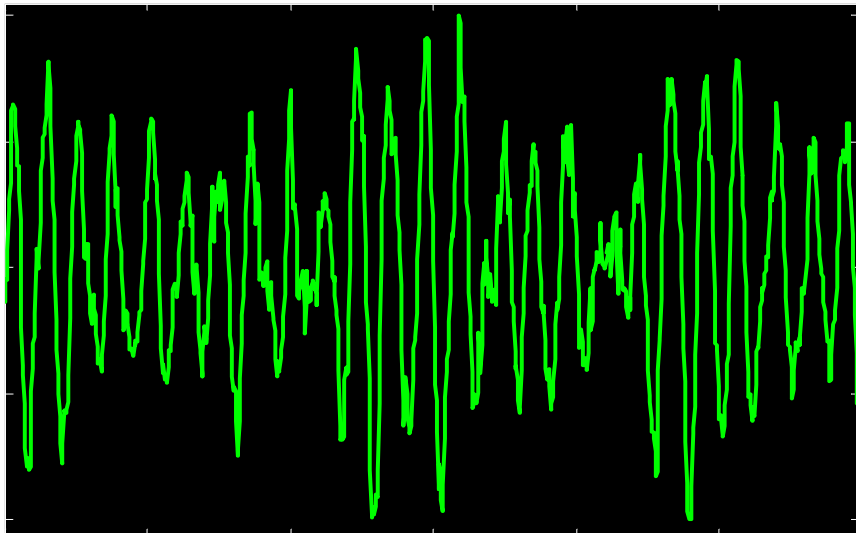

AM (modulation index =1)

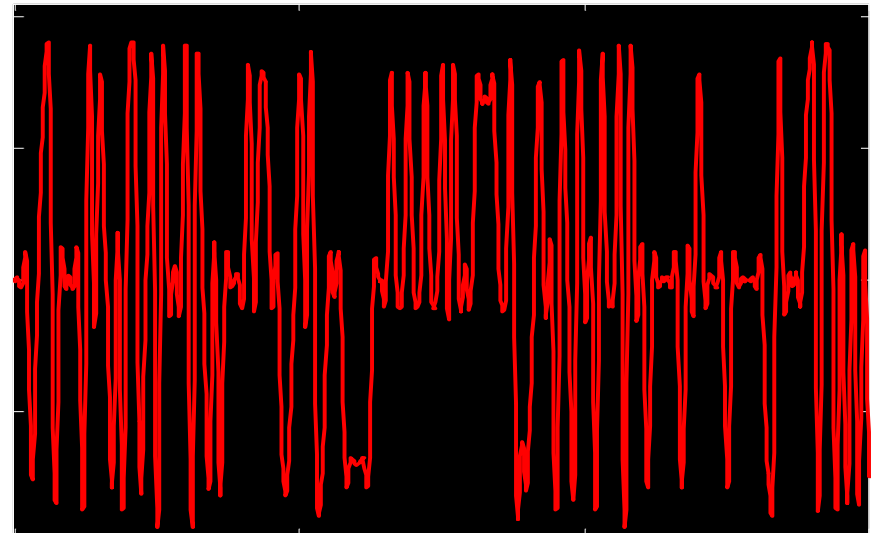

BPSK (pulse-shaping roll-off = 0.5)

Waveform Features in Time Domain

σ_a	- Standard deviation of the signal amplitude
σ_{ENV}	- Standard deviation of signal envelope
σ_ϕ	- Standard deviation of the phase
$\sigma_{\Delta\phi}$	- Standard deviation of the change in phase
$\sigma_{ \Delta\phi }$	- Standard deviation of the absolute value of the phase change

- Only five basic statistics need to be calculated
- Represent up to second-order statistics It isn't clear to me what this means
- Phase information is emphasized because
 - More sensitive to different modulation schemes
 - Less sensitive to noise than instantaneous amplitude and frequency
- In MATLAB, the average time to classify is 0.01 seconds for feature extraction and 0.025 seconds for classification

A Typical Performance with AWGN

Table 1. Success Rate of Classification

Modulation	Probability of Success for SNR			
	10 dB	20 dB	50 dB	100 dB
AM	94.0	99.0	100.0	99.0
FM	100.0	100.0	100.0	100.0
BPSK	100.0	100.0	100.0	100.0
QPSK	64.0	86.0	92.0	90.0
BFSK	43.0	100.0	100.0	100.0
QAM8	34.0	34.0	62.0	59.0
QAM16	67.0	64.0	73.0	88.0
Overall	68.7	83.3	89.6	90.9

What causes the problem at low SNR ?

Modulation Schemes in Feature Space

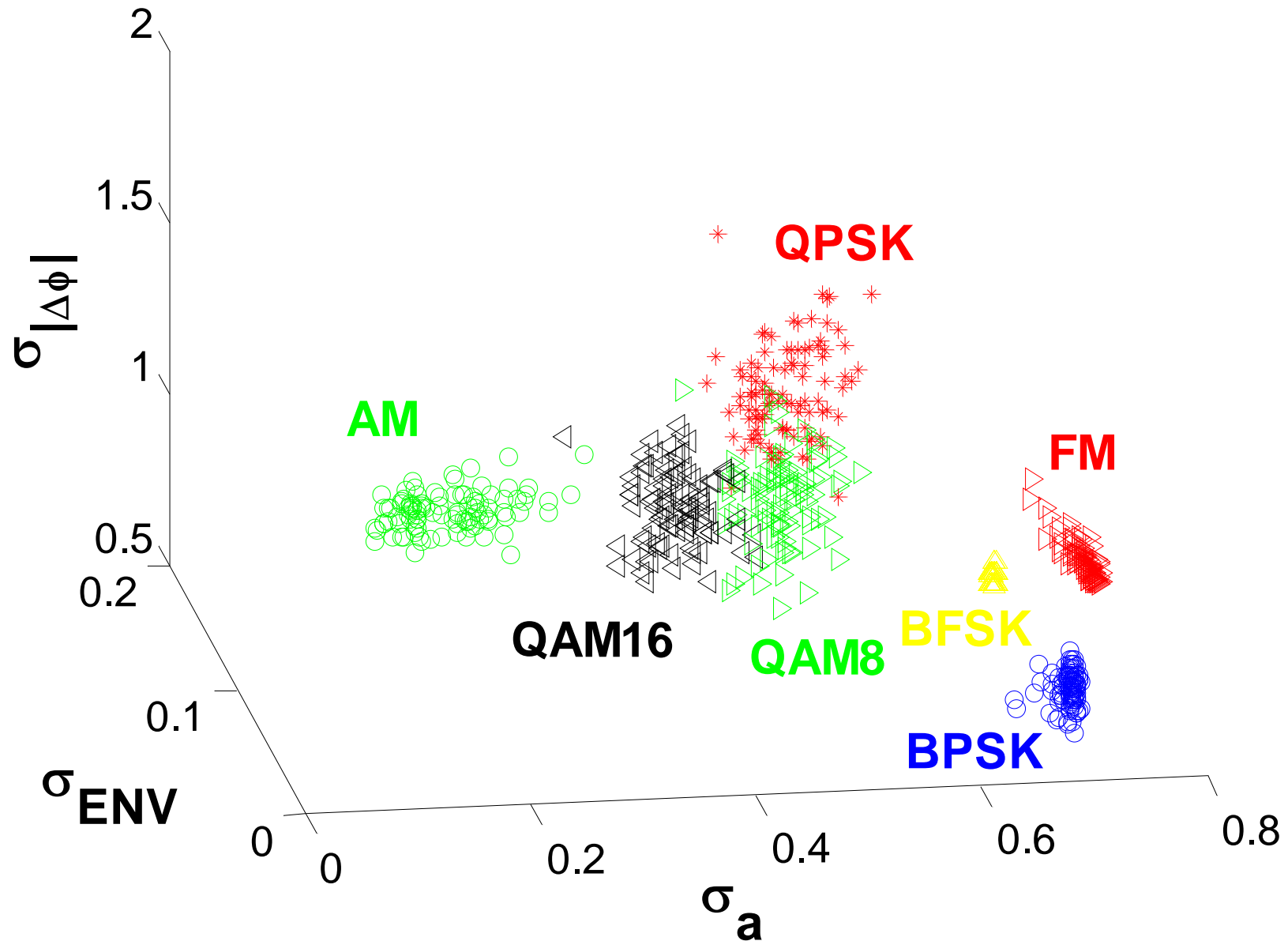

Modulation Schemes in Feature Space

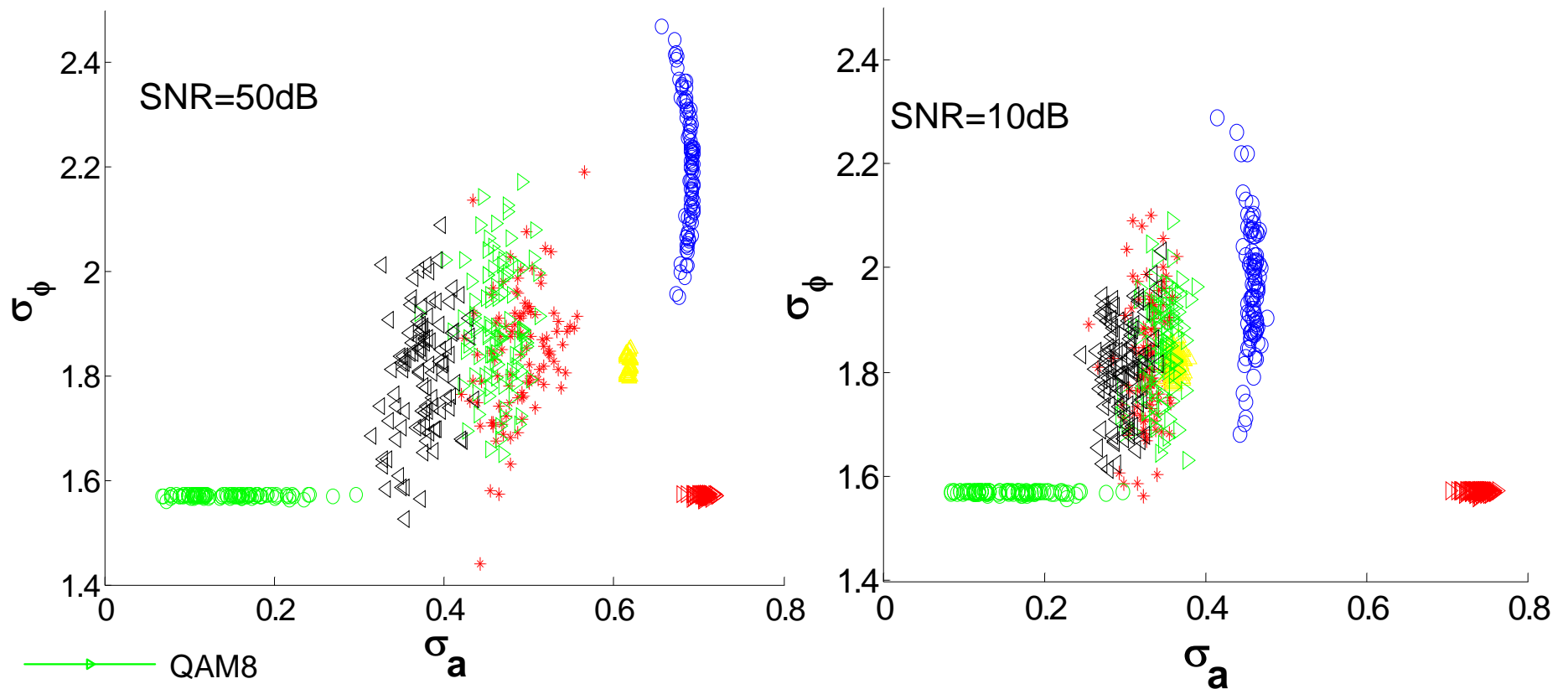

- QAM8
- QAM16
- AM
- FM
- BPSK
- QPSK
- BFSK

- Separation reduced by noise
- Differentiation is determined by feature space definition
- Trade-off between computational cost and performance
- Trade-off between network size and nonlinearity

How Dimension Helps

Modulation signals at SNR = 10 dB :

- QAM8
- QAM16
- AM
- FM
- BPSK
- QPSK
- BFSK

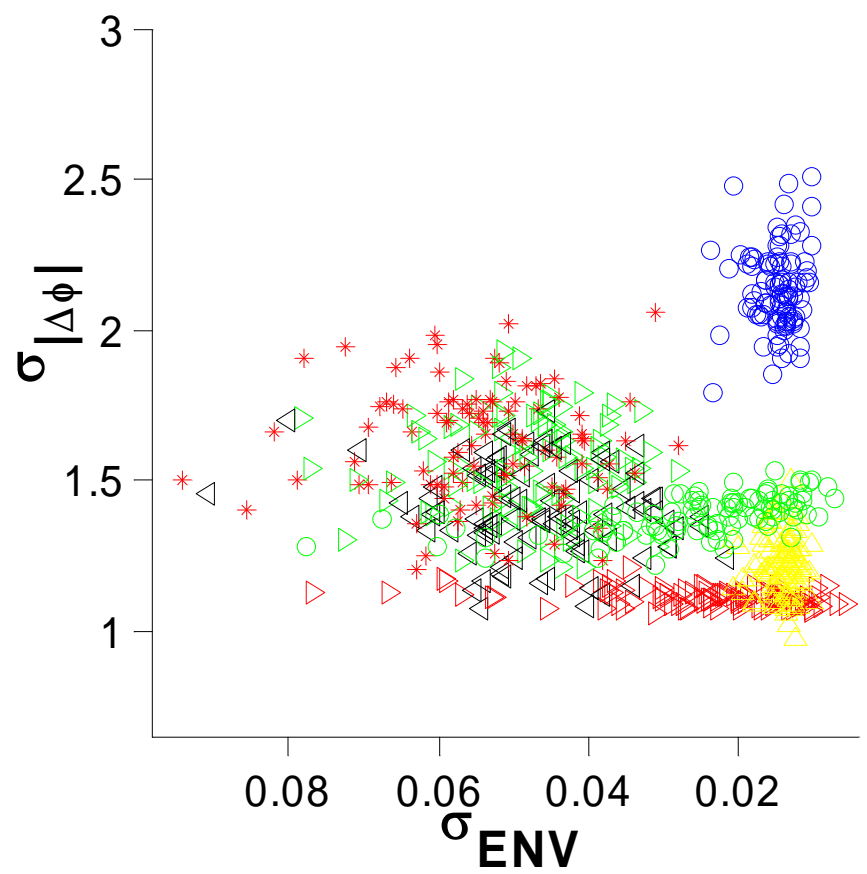

Two-dimension feature sub-space

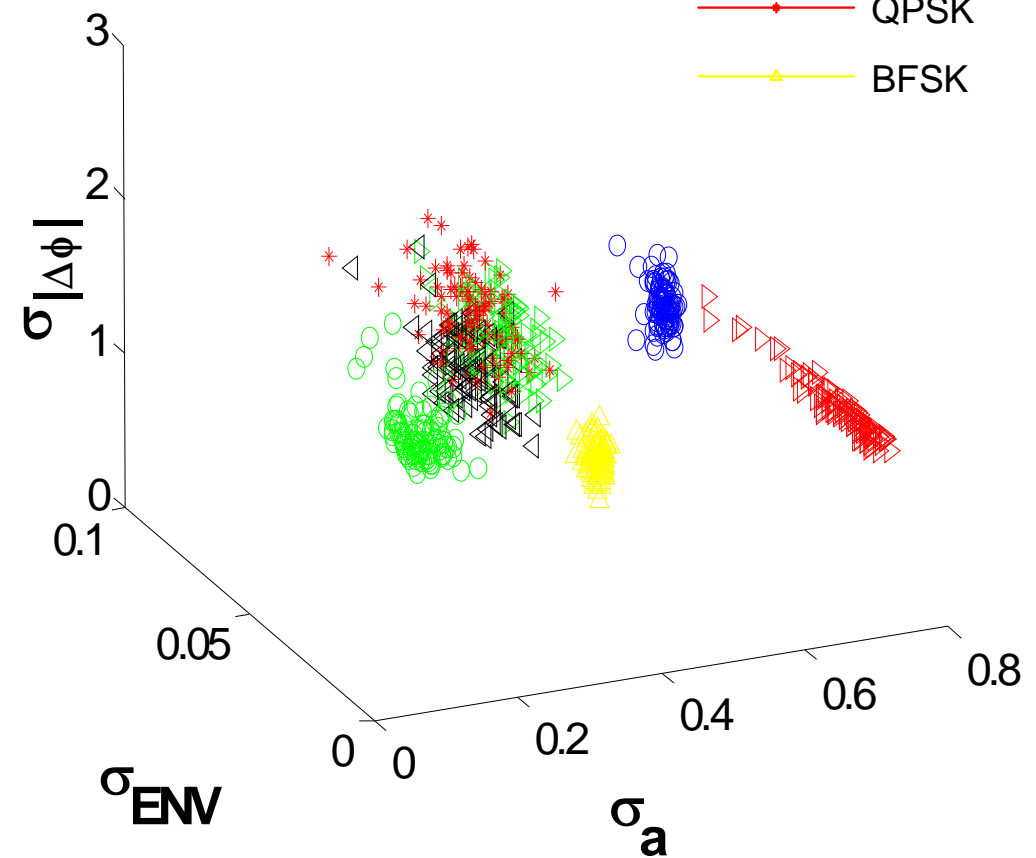

Three-dimension feature sub-space

Status of Work

- New network design of parallel OCONs as opposed to conventional single MLPN
- Analysis of the signal feature space for various modulation schemes that no paper did before
- Illustration of the difficulty in QAM modulations that no paper explained before
- Combinatorial signal identification approach is under CWT's current research

Acknowledgement

- This project is supported by Award No. 2005-IJ-CX-K017 awarded by the National Institute of Justice, Office of Justice Programs, US Department of Justice. The opinions, findings, and conclusions or recommendations expressed in this publication/program/exhibition are those of the author(s) and do not necessarily reflect the views of the Department of Justice.
- This material is based upon work supported by the National Science Foundation under Grant No. CNS-0519959. Any opinions, findings and conclusions or recommendations expressed in this material are those of the author(s) and do not necessarily reflect the views of the National Science Foundation (NSF).



National Institute of Justice

The Research, Development, and Evaluation Agency of the U.S. Department of Justice

