

# COGNITIVE RADIOS WITH GENETIC ALGORITHMS: INTELLIGENT CONTROL OF SOFTWARE DEFINED RADIOS

Thomas W. Rondeau,  
Bin Le, Christian J. Rieser, Charles W. Bostian



Center for Wireless Telecommunications (CWT)  
Virginia Tech  
Blacksburg, VA, 24061

# Motivation

- Why Cognitive Radios?
  - Modern radios provide us with powerful, flexible radios
  - Numerous parameters to create highly adjustable waveforms
  - Variable radio environments cause unexpected and non-intuitive behavior
  - Need to put the intelligence in the radio and reduce demands on the user
- This presentation discusses a method we developed to intelligently adapt radios

# Cognitive Radio Overview

- At their most basic, Cognitive Radios are:
  - **Aware**: it can sense, perceive, and collect information about its environment
  - **Intelligent**: it can process and learn about the environment and its own behavior
  - **Adaptive**: it can use what it knows to alter the radio's behavior to improve communication for itself and the surrounding radios
- We use **biologically-inspired** techniques that combine machine learning with genetic and evolutionary algorithms

# Biological Adaptation

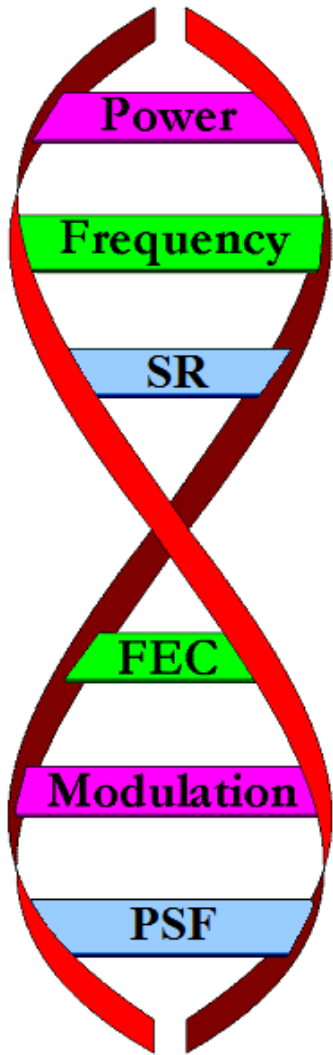

- Intelligent adaptation is done using **genetic algorithms** (GAs)
- Radio is modeled as a biological system where traits are defined by a **chromosome**
- Each gene of the chromosome corresponds to one **adjustable parameter** of the radio
- The GA optimizes the chromosome to provide the user with a **quality of service**

# Intro to Genetic Algorithms

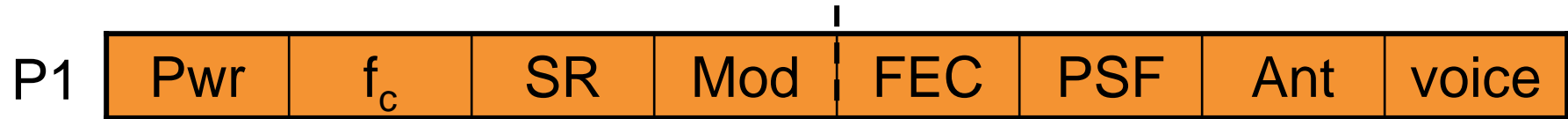

Crossover Operation:



Mutation Operation on Offspring 1:



# Multi-Objective Decision Making

- Choosing the radio parameters to provide a QoS is a **multi-objective decision making** (MODM) problem
  - No one single objective can properly satisfy user needs in all situations
  - Analysis in BER/SER, PER, data rate, network latency and jitter, power consumption
- Some of these listed parameters are **competing objectives**, so the decision is a trade-off in many dimensions
- Basic formula for MODM problem:

$$\min/ \max \{\bar{y}\} = f(\bar{x}) = [f_1(\bar{x}), f_2(\bar{x}), \dots, f_n(\bar{x})]$$

$$\text{subject to: } \bar{x} = (x_1, x_2, \dots, x_m) \in X$$

$$\bar{y} = (y_1, y_2, \dots, y_n) \in Y$$

# Multi-Objective Genetic Algorithms

- GAs are well-suited to solving MODM problems
  - Parallel analysis of many solutions in many dimensions
  - Called a **Multi-Objective Genetic Algorithm (MOGA)**
- The most fit chromosome is the one that **dominates** the other chromosomes in the all dimensions
  - Moves towards the **Pareto-optimal** front

# Decision Weighting

- *Weights* are associated with each objective to indicate its importance
- Competition compares two chromosomes at a time
  - The winner in each dimension has its fitness incremented by the weight of that dimension
  - The chromosome with the highest fitness value wins the tournament
- The competition is repeated for all members of the population, and the winners survive to the next generation

# WSGA

- The WSGA is the MOGA we have developed to solve for the MODM radio problem
- The objectives are mathematical approximations of a the radio given the current channel conditions and solving for the user's required QoS
- Objectives: *power*, *BER*, PER, *data rate*, *occupied bandwidth*, *spectral efficiency*, network latency and jitter, etc.

# Results – Hardware Testbed

## Adapt Proxim *Tsunami* radios

### Adapting with limited range of parameters:

- Modulation: QPSK, QAM8, QAM16
- Power: 6 dBm – 17 dBm
- Frequency: See figure on left
- Uplink/Downlink ratio

Even with this limited-flexibility **legacy** radio, we can use our cognitive processes to **adapt** the radio, including the avoidance of an interferer.

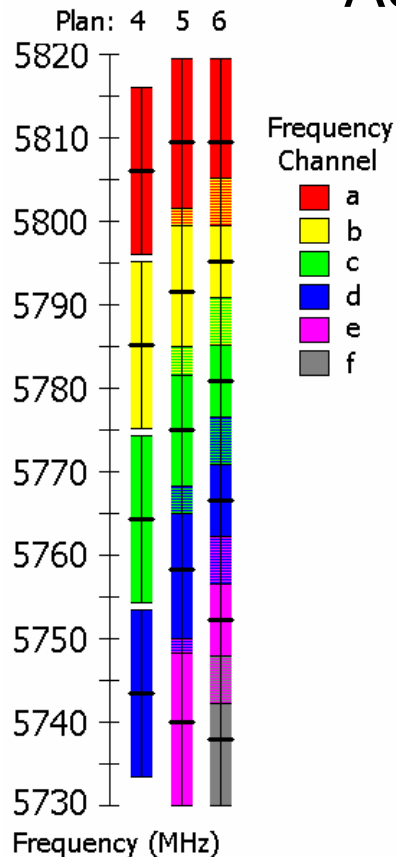

Frequency Channels available to Proxim Tsunamis

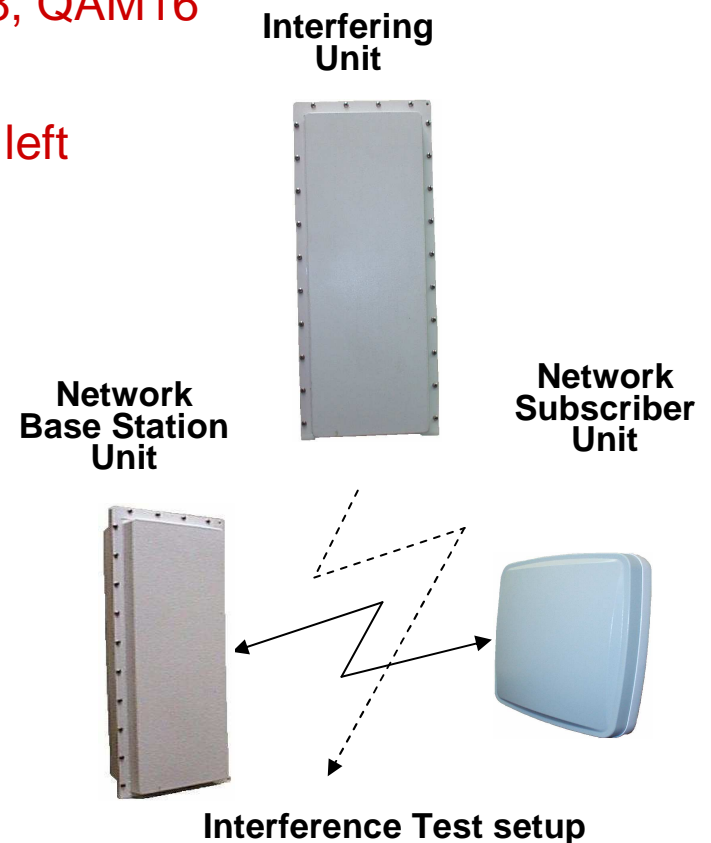

# Hardware Testbed Results

## WSGA Genetic Parameters

Parameter	Value
Crossover Rate	90 %
Mutation Rate	5 %
Population Size	30
Replacement Sizw	20
Max Generations	50

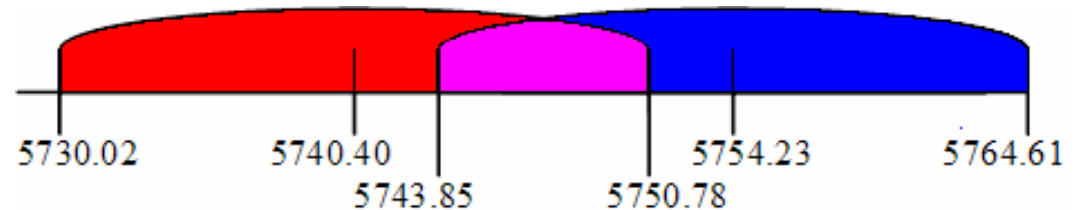

**Interference Test Spectrum (MHz)**

Data collected before interference, before WSGA was run with interference, and after GA was optimized with different objectives

## Objective Weighting

Objective	GA1	GA2
BER min.	200	255
Power min.	210	0
Data rate max.	0	0

# Hardware Testbed Results

<b>Parameters and Packet Error Rate Results</b>				
	<b>No Int.</b>	<b>Pre-GA</b>	<b>Post-GA1</b>	<b>Post-GA2</b>
<b>Power (dBm)</b>	6	17	7	17
<b>Modulation</b>	QAM16	QAM16	QPSK	QPSK
<b>TDD (%)</b>	50	50	75	50
<b>FEC rate</b>	3/4	3/4	1/2	3/4
<b>BSU-SU</b>	0	2.09x10 <sup>-2</sup>	2x10 <sup>-4</sup>	1x10 <sup>-3</sup>
<b>SU-BSU</b>	0	0.8603	0.4752	1x10 <sup>-4</sup>

- Resulted in improved performance
- Limited adaptable parameters make finding the solution a trivial problem
- Need more comprehensive platform to test

# Software Simulation

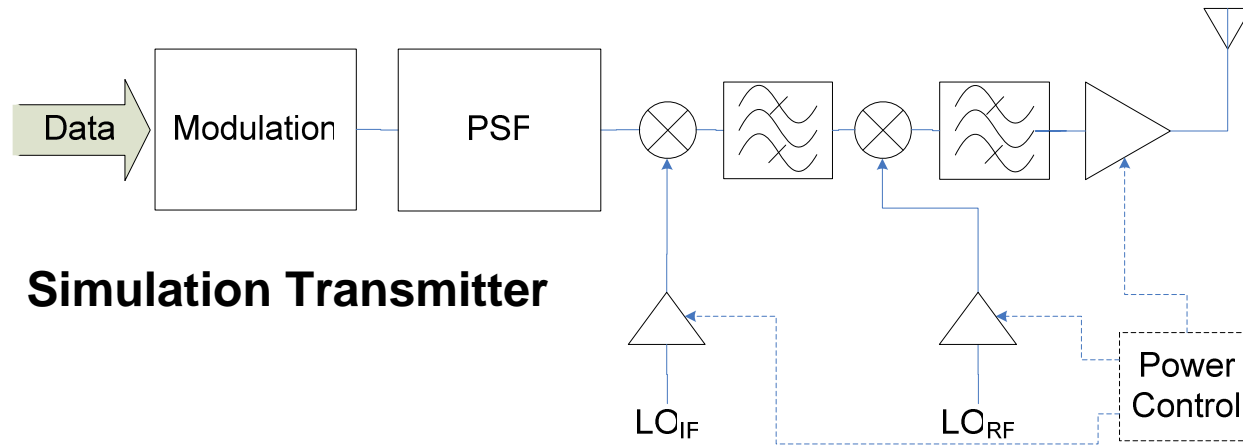

<b>Simulation Adaptable Parameters</b>	
<b>Parameters</b>	<b>Range</b>
Power (dBm)	0 – 30
Frequency (MHz)	2400 – 2480
Modulation	M-PSK, M-QAM
Modulation, M	2 – 64
PSF roll-off factor	0.01 – 1
PSF order	5 – 50
Symbol Rate (Msps)	1 - 20

Developed software simulation in MatLab to simulate the physical layer of a software defined radio

# Reduce Spectral Occupancy – Allow others to use my unused spectrum

For instances of small amounts of data, we can reduce the spectral occupancy by giving highest weighting to bandwidth and power minimization

Power	18 dBm
Symbol Rate	1 Msps
Center Frequency	2440 MHz
Modulation	BPSK
PSF roll-off	0.05
PSF order	46
BER	0
Data Rate	1 Mbps

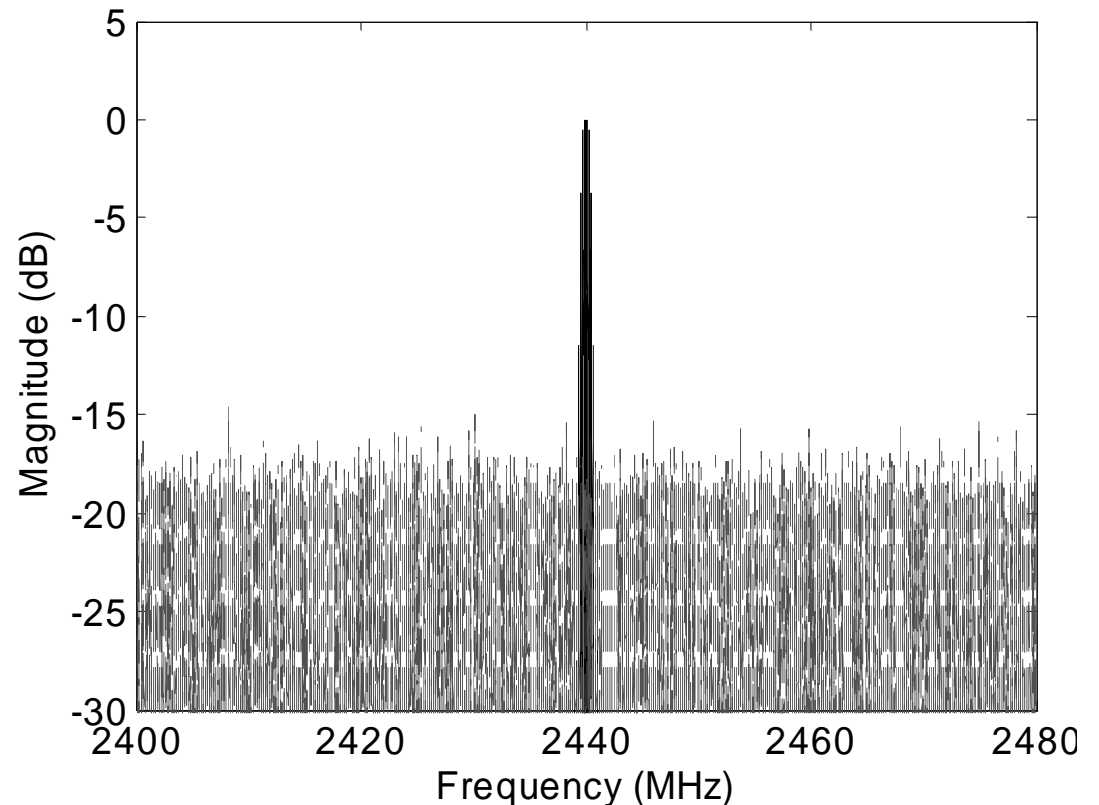

# Increase Spectrum Occupancy – Use the provided resources

The CR can support high-speed data networks by using the bandwidth available by giving the highest weighting to the data rate

Power	28 dBm
Symbol Rate	18 Msps
Center Frequency	2430 MHz
Modulation	QAM16
PSF roll-off	0.33
PSF order	20
BER	0
Data Rate	72 Mbps

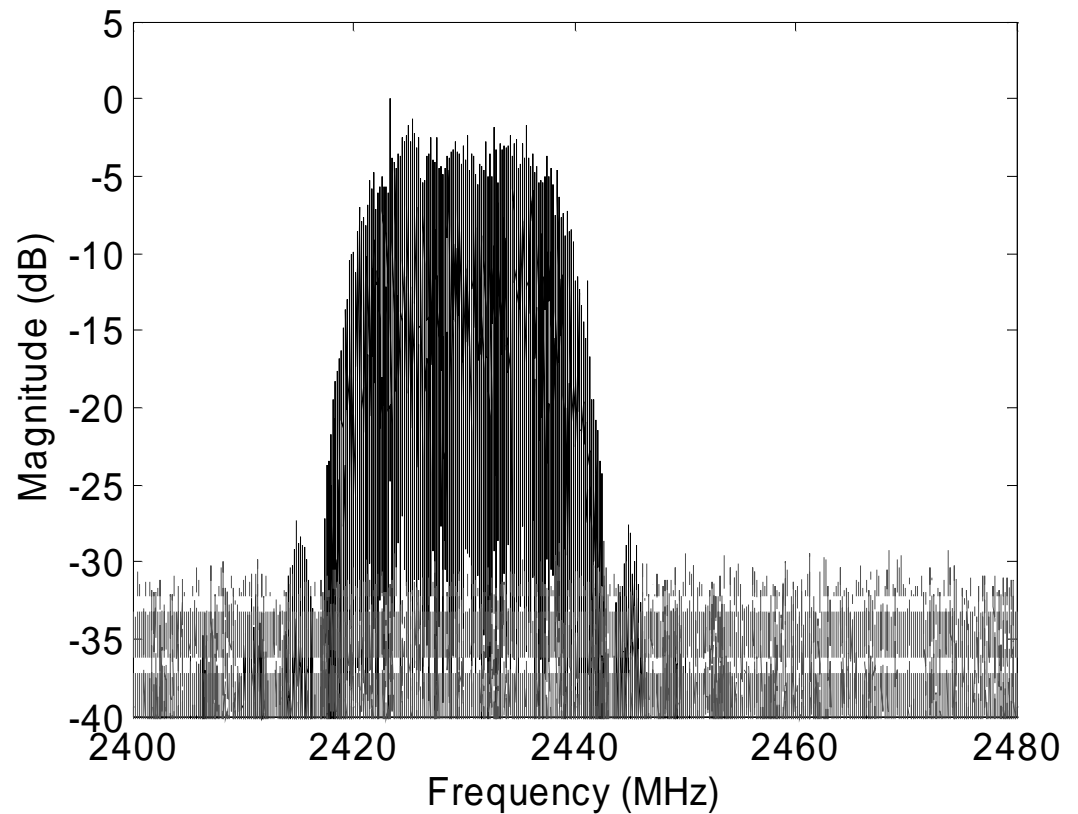

# Work with Existing Users - Respect regulations and licensed users

Interference avoidance and BER minimization were ranked as the highest objectives

Power	29 dBm
Symbol Rate	3 Msps
Center Frequency	2436 MHz
Modulation	QPSK
PSF roll-off	0.04
PSF order	18
BER	0
Data Rate	6 Mbps

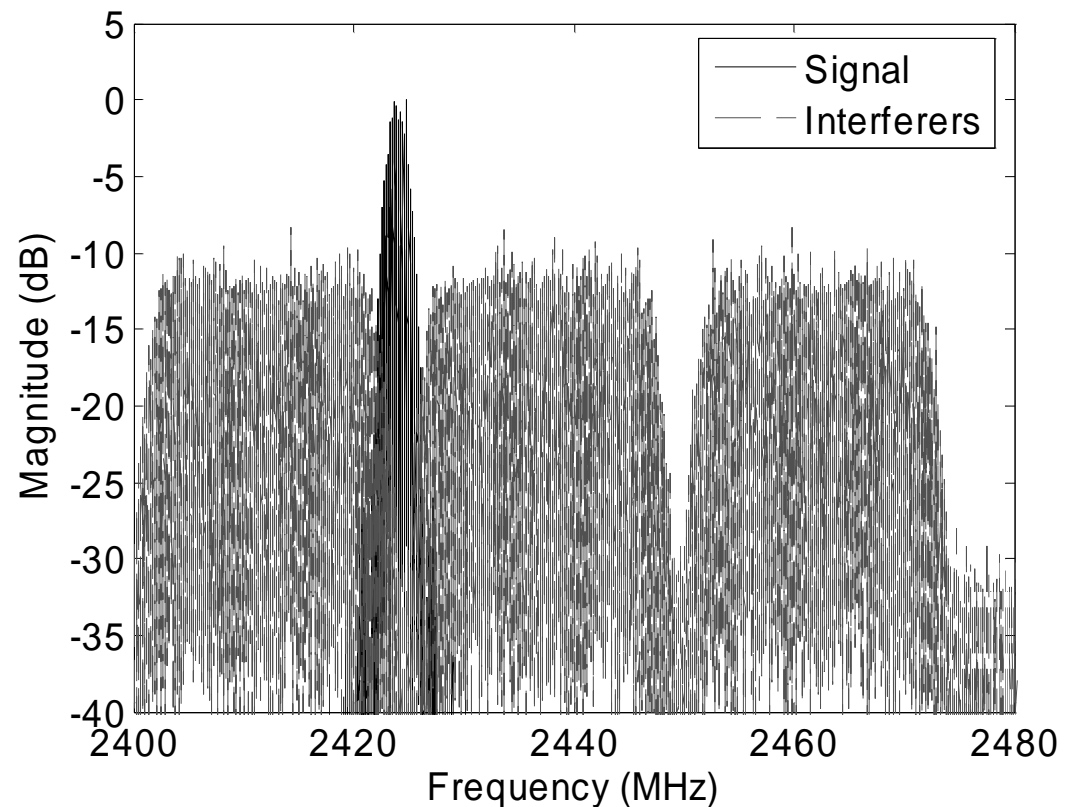

# Work with Existing Users - But mistakes can still happen!

The delicate balance of parameters on the Pareto-optimal front can lead to undesirable output if the GA is terminated too quickly or the weightings do not properly represent the scenario

Power	23 dBm
Symbol Rate	8 Msps
Center Frequency	2436 MHz
Modulation	QAM8
PSF roll-off	0.04
PSF order	13
BER	0
Data Rate	24 Mbps

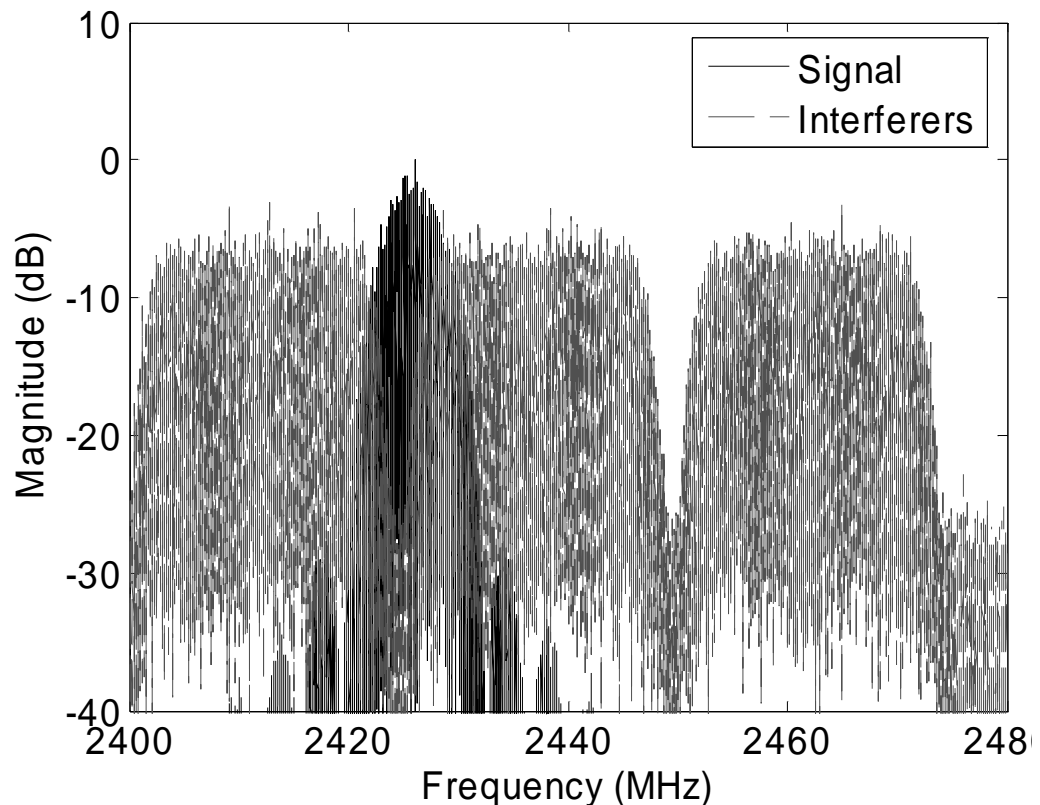

# Problems

- Need better **sensing** and **modeling** of channel
- Need to improve the simulation and get better hardware to show power of our CR approach
  - Working on improving the simulation to include more **PHY layer** parameters (Spread Spectrum, more modulations, etc.) and add **MAC layer** parameters (FEC, interleaving, source coding, duplexing, etc.)
  - Looking to software radio platforms for future hardware tests
- Improve the WSGA performance by using **niching, migration, and adaptable GA parameters**
  - This along with the machine learning will help prevent the problems experienced in the final WSGA experiment

# Conclusions

- The genetic algorithm is a power and efficient method to adapting radios while considering multiple objectives
- We have proven this technique in both hardware and software
- Trading off **tuning knobs** for **tuning weights**
  - The weights directly represent the performance, which can be easily analyzed and adjusted by an intelligent machine
  - We are currently working on developing this machine intelligence

# Questions?

## Contact Information

Thomas W. Rondeau

[trondeau@vt.edu](mailto:trondeau@vt.edu)

Bin Le

[binle@vt.edu](mailto:binle@vt.edu)

Charles W. Bostian

[bostian@vt.edu](mailto:bostian@vt.edu)

<http://www.cwt.vt.edu>

540-231-5096



This work was supported by the National Science Foundation under awards 9983463 and *DGE-9987586*.

