

# Cognitive Software Defined Radio:

Applications of Cognitive SDR using  
the GNU Radio and the USRP

09/09/05

David Scaperoth

# Overview

## (1) Software Defined Radio

- Definition
- Pros and Cons
- Applications

## (2) Cognitive Radio

- Definition
- Pros and Cons
- Applications

## (3) GNU Radio and the USRP

- Definition
- How are we using it now?

## (4) Future Work with CR and GNU Radios

# Cognitive Radio

- “Turning the Knobs”
  - responds to the operator’s commands by configuring the radio
- “Reading the Meters”
  - monitors its own performance continuously

# Cognitive Radio

- Knobs and Meters

## Software Defined Radio (SDR)

- The Cognitive Engine *tells* the radio how to control the knobs and meters.

# Cognitive Radio

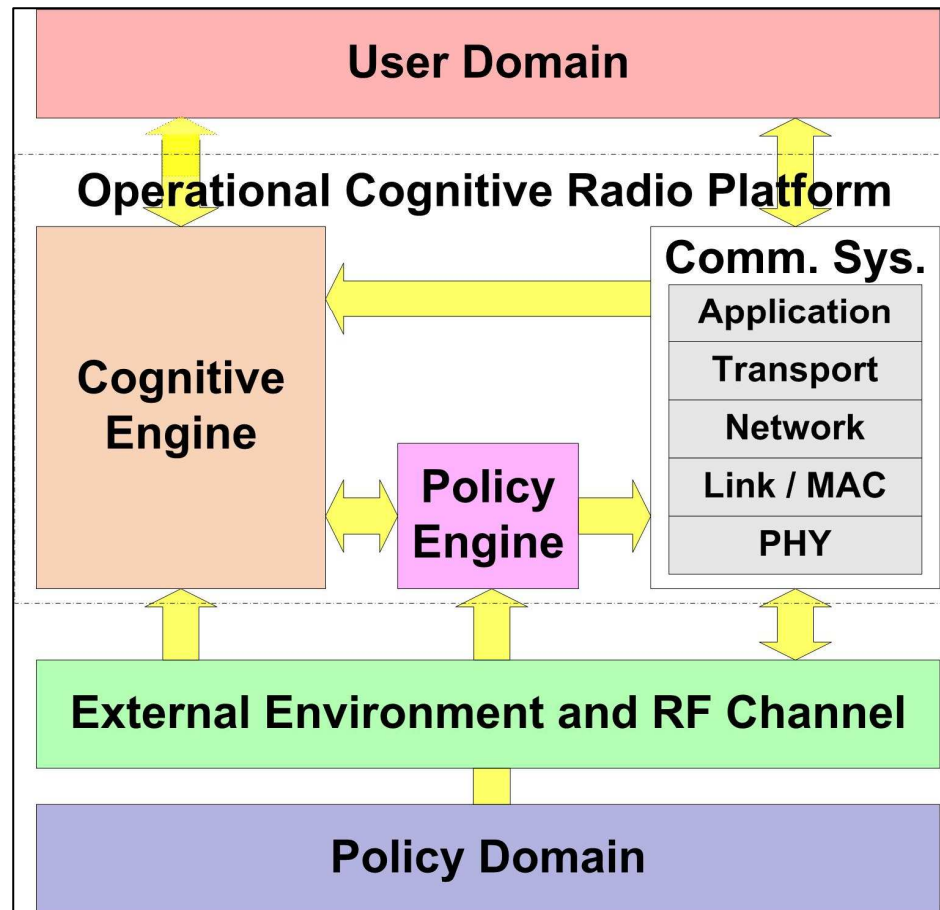

# Cognitive Radio

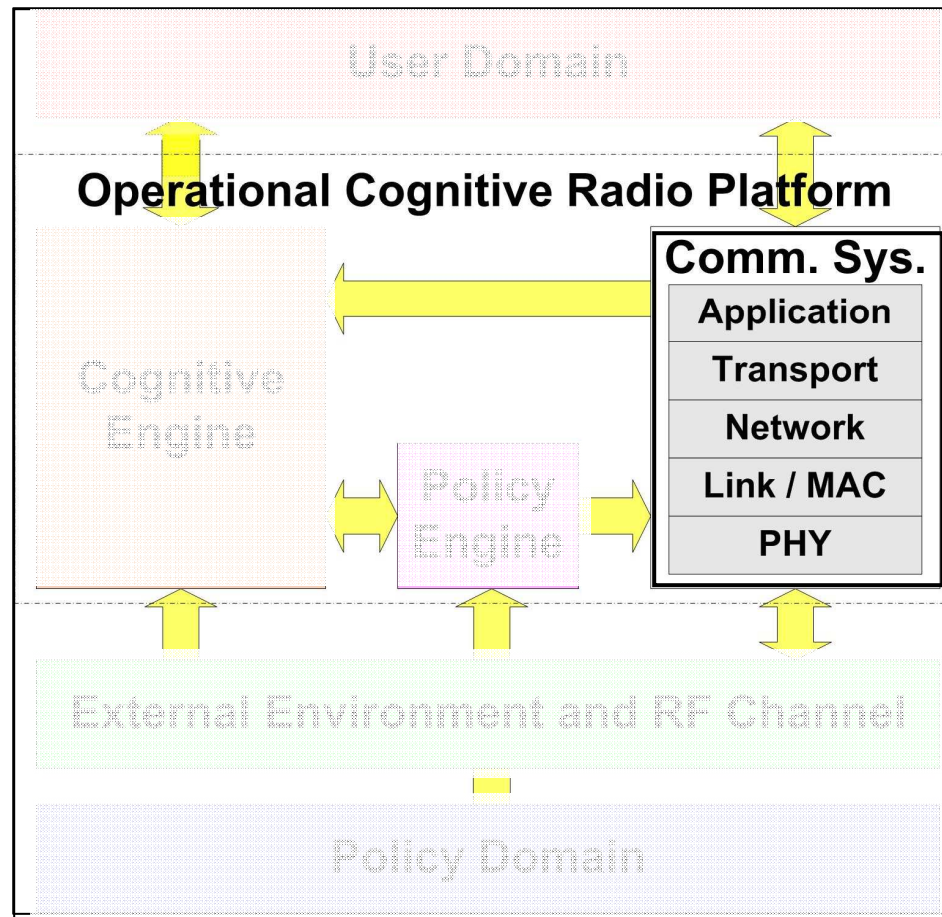

# Software Defined Radio (SDR)

- Broad Range of Definitions
- John Mitola ('92) - radio primarily defined in software, which supports a broad range of frequencies, and its initial configurations can be modified for user requirements.
- Dr. Jeffery Reed - A flexible radio that can be able to accommodate formats and protocols *yet to be determined*.
- Not necessarily a microprocessor - much more flexible.

# Radio Architecture

## Superhetrodyne

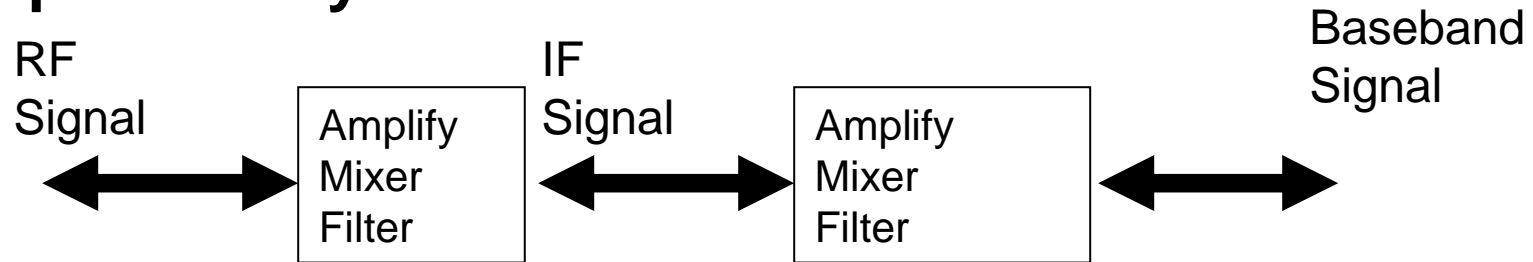

## Software Defined Radio

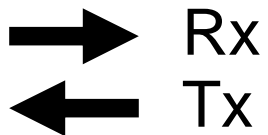
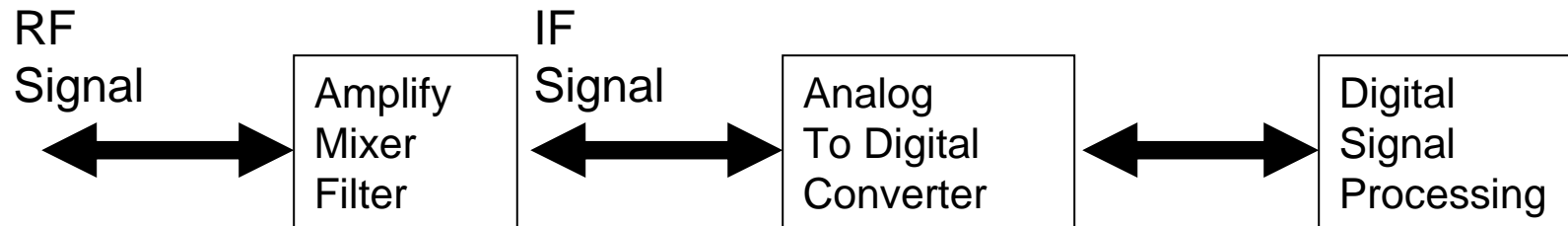

# Software Defined Radios

- Pros
  - Flexibility
  - Reduced parts inventory
  - DSP can compensate for cheaper RF
  - Faster Time to Market
- Cons
  - Software Reliability
  - Security
  - Cost
  - Power Consumption

# Software Defined Radios

- Applications
  - Predistortion and Pulse Shaping
  - Voice Recognition
  - Cognitive Functions
- Real World Applications
  - Military: Full Connectivity between branches
  - Commercial: Lower Cost Networks, Base Units, etc.

# Cognitive Radio

- Broad Range of Definitions
- Mitola ('99) - Software Radio that is aware of its environment and its capabilities
- Learns from previous experience

# Cognitive Radio

- Pros
  - Same as SDR
  - Utilize scarcity of the spectrum
  - Full Connectivity between channels, waveforms, etc.
  - Potentially create new waveforms.
- Cons
  - Same as SDR
  - Complexity (S/W and H/W)
  - Standardization (FCC)

# Cognitive Radio

## Applications

- Regulatory:
  - Utilize dynamic spectrum access
  - Communicate between radio standards
- Military
  - Interoperability with different branches
  - Recognize enemy devices and protecting communication
- Public Safety
  - Interoperability with emergency response and public safety regions from around the world.

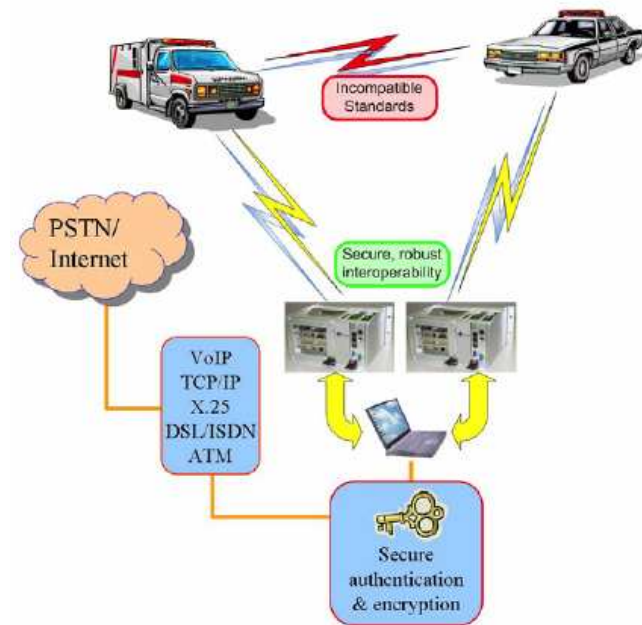

How are we going to make a  
Cognitive Radio?

**GNU Radio!**

# How are we going to make a Cognitive Radio?

- What is GNU Radio?
  - GNU Radio is a set of S/W signal processing building blocks that allow users to create their own S/W radio
- Why GNU Radio?
  - Attempts to solve the complexity issues of both H/W and S/W of SDR
  - Modular (use with most any GPP)
    - S/W used on Windows, Linux, Mac

# Example: Simple AM Transmitter (1/2)

## Building Blocks

- All Blocks are each defined as objects

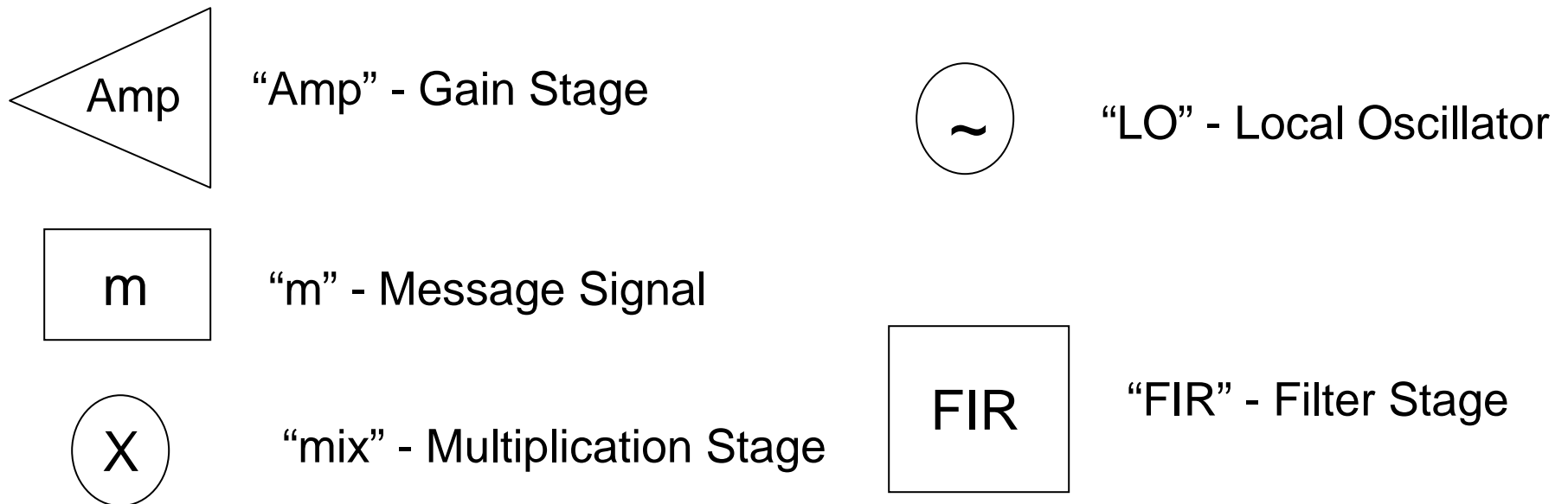

# Example: Simple AM Transmitter (2/2)

## Connecting Building Blocks

- The arrow is an object that connects the flow graph

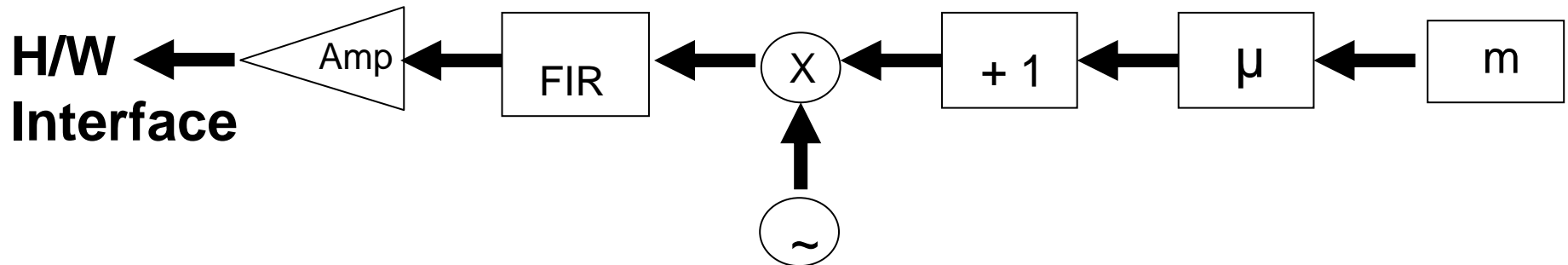

# How are we going to make a Cognitive Radio?

USRP - Universal Software  
Radio Peripheral

GNU Radio software  
- core s/w  
- user made s/w

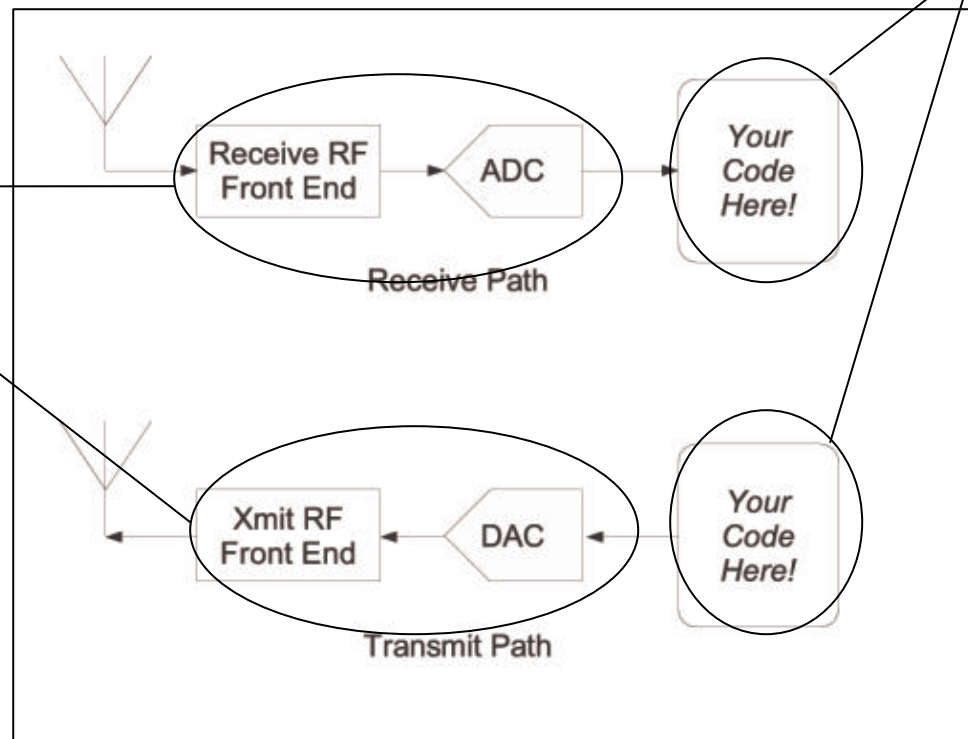
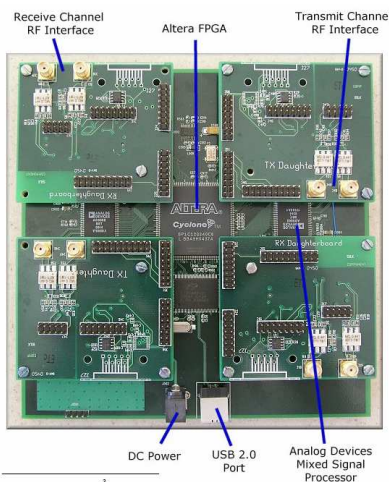

GNU Radio S/W  
available at [www.gnuradio.org](http://www.gnuradio.org)

# USRP

4 ADC's:

- 12bits per second, 64MSps,
- Analog Input BW over 200Mhz

4 DAC's

- 14bits per second, 128MSps

Transmit Channel RF Interface

Receive Channel RF Interface

DC Power

USB 2.0  
Port

Analog Devices  
Mixed Signal  
Processor

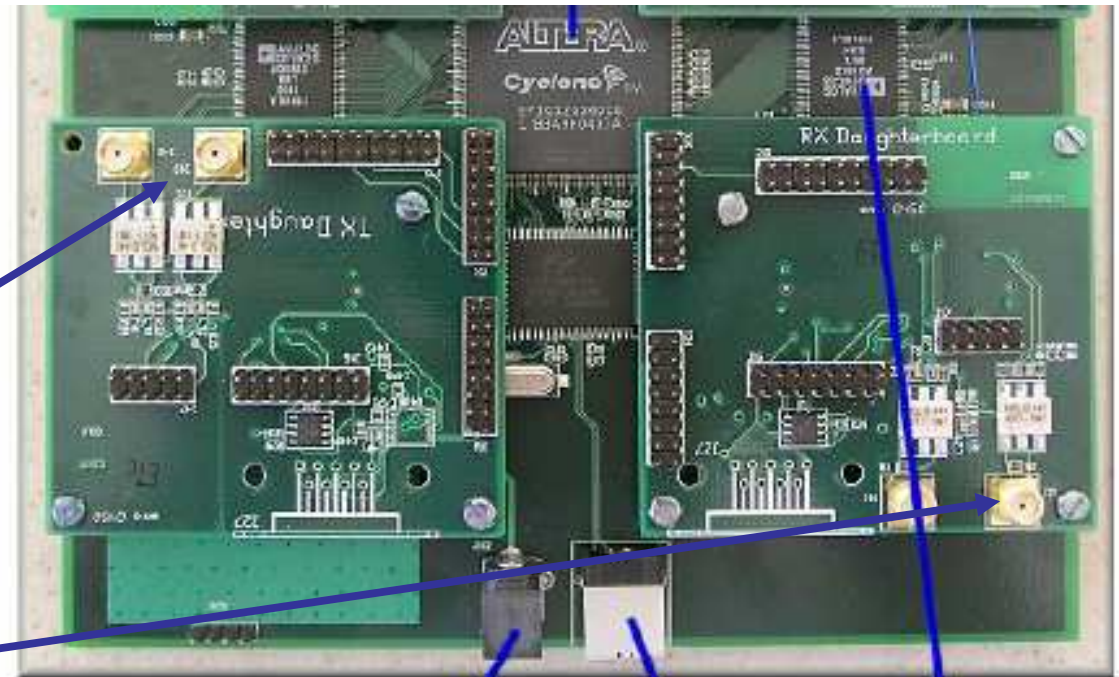

# Cognitive Radio

- “Turning the Knobs”
  - responds to the operator’s commands by configuring the radio
- “Reading the Meters”
  - monitors its own performance continuously

# GNU Radio and Cognitive Radio

- Turning Knobs
  - Center Frequency, Modulation (dig/analog), Symbol Rate, Pulse Shape Filter: type and shape factor, Spreading, Power
- Knobs of the near future
  - Channel coding: interleaving, Encryption, MAC-layer techniques: TDMA, FDMA, CDMA, equalization...

# GNU Radio and Cognitive Radio

- Reading Meters
  - BER, FER (Frame Error Rate), Data Rate, Receive Signal Power, Noise Power - SINR
- Meters of the future:
  - Doppler Effect, Angle of arrival, etc.

# What is CWT doing with GNU Radio?

- Modeling Standard Radio Protocols
  - FM
  - P.25
- Simulate a detection environment for wanted signals and unwanted waveforms
- Cognitive Engine Testing

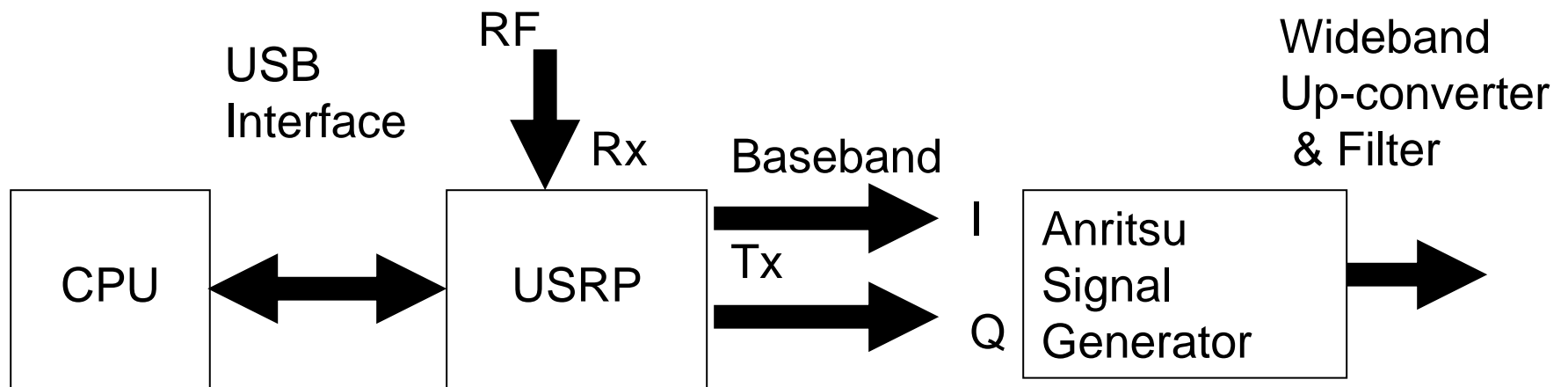

# The Future of GNU Radio

## Full Testing with Cognitive Engine

- Point to Point & Network Analysis
- Rutgers ORBIT facility and University of Utah's Emulab will make large scale simulations possible

Any Questions?